

Professional IP Phone with 3 Lines & HD Voice

Yealink SIP-T23G features intuitive user interface and enhanced functionality which make it easy for people to interact and maximize productivity. Yealink HD technology enables rich, clear, life-like voice communications, outsourced management options, flexible deployment and third-party communications applications. As a cost-effective IP solution, it helps users to streamline business processes, delivery a powerful, security and consistent communication experience for small and large offices environment.



Key Features and Benefits

HD Audio

Yealink HD voice refers to the combination of software and hardware design as well as the implementation of wideband technology to maximize the acoustic performance. Coupled with advanced acoustic clarity technology such as full duplex, echo cancellation, adaptive jitter buffer etc., the SIP-T23G provides clearer, more lifelike voice communications.

Enhanced Call Management

The SIP-T23G supports vast productivity-enhancing features such as XML Browser, call park, call pickup, BLF, call forward, call transfer, 3-way conference, which makes it the natural and obvious efficiency tool for today's busy small and large offices environment.

Efficient Installation and Provisioning

The Yealink SIP-T23G supports efficient provisioning and effortless mass deployment with Yealink's Redirection and Provisioning Service (RPS) and Boot mechanism to help you realize the Zero Touch Provisioning without any complex manual settings, which makes the SIP-T23G simple to deploy, easy to maintain and upgrade.

Highly secure transport and interoperability

The communicator uses SIP over Transport Layer Security (TLS/SSL) to provide service providers with the latest technology for enhanced network security. The range is certified compatible with 3CX and Broadsoft Broadworks, ensuring excellent compatibility with leading soft switch suppliers.

- > Yealink HD Voice
- > Dual-port Gigabit Ethernet
- > PoE support
- > 132 x 64-pixel graphical LCD
- > Up to 3 SIP accounts
- > Opus codec support
- > Supports Dual-color LEDs
- > Headset support
- > Wall mountable
- > IPv6 support
- > Paperless design
- > Simple, flexible and secure provisioning options

Audio Features

- > HD voice: HD handset, HD speaker
- > Wideband codec: Opus, G.722
- > Narrowband codec: G.711(A/μ), G.729AB, G.726, iLBC
- > DTMF: In-band, Out-of-band (RFC 2833) and SIP INFO
- > Full-duplex hands-free speakerphone with AEC
- > VAD, CNG, AEC, PLC, AJB, AGC

Phone Features

- > 3 SIP accounts
- > Call hold, mute, DND
- > One-touch speed dial, hotline
- > Call forward, call waiting, call transfer
- > Group listening, SMS
- > Redial, call return, auto answer
- > Local 3-way conferencing
- > Direct IP call without SIP proxy
- > Ring tone selection/import/delete
- > Set date time manually or automatically
- > Dial plan, off hook hot line
- > XML Browser, Action URL/URI
- > Integrated screenshots
- > RTCP-XR
- > Enhanced DSS Key

Directory

- > Local phonebook up to 1000 entries
- > Black list
- > XML/LDAP remote phonebook
- > Smart dialing
- > Phonebook search/import/export
- > Call history: dialed/received/missed/forwarded

IP-PBX Features

- > Busy Lamp Field (BLF), Bridged Line Appearance (BLA)
- > Anonymous call, anonymous call rejection
- > Hot-desking, emergency call
- > Message Waiting Indicator (MWI)
- > Voice mail, call park, call pickup
- > Intercom, paging, music on hold
- > Call completion, call recording
- > Flexible seating
- > Executive and Assistant
- > Centralized call recording
- > Visual voice mail

Display and Indicator

- > 132 x 64-pixel graphical LCD with backlight
- > LED for call and message waiting indication
- > Dual-color (red or green) illuminated LEDs for line status information
- > Intuitive user interface with icons and soft keys
- > Multilingual user interface
- > Caller ID with name and number
- > Power saving

Feature keys

- > 3 line keys with LED
- > 5 features keys: message, headset, redial, transfer, hands-free speakerphone
- > 6 navigation keys
- > Volume control keys

Interface

- > Dual-port Gigabit Ethernet
- > Power over Ethernet (IEEE 802.3af), class 2
- > 1 x RJ9 (4P4C) handset port
- > 1 x RJ9 (4P4C) headset port

Other Physical Features

- > Wall mountable
- > External Yealink AC adapter (optional): AC 100~240V input and DC 5V/600mA output
- > Power consumption (PSU): 0.7-1.5W
- > Power consumption (PoE): 1.0-2.2W
- > Dimension (W*D*H*T): 209mm*188mm*150mm*41mm
- > Operating humidity: 10~95%
- > Operating temperature: -10~50°C (+14~122°F)

Management

- > Configuration: browser/phone/auto-provision
- > Auto provision via FTP/TFTP/HTTP/HTTPS for mass deploy
- > Auto-provision with PnP
- > Zero-sp-touch, TR-069
- > Phone lock for personal privacy protection
- > Reset to factory, reboot
- > Package tracing export, system log

Network and Security

- > SIP v1 (RFC2543), v2 (RFC3261)
- > Call server redundancy supported
- > NAT traversal: STUN mode
- > Proxy mode and peer-to-peer SIP link mode
- > IP assignment: static/DHCP
- > HTTP/HTTPS web server
- > Time and date synchronization using SNTP
- > UDP/TCP/DNS-SRV (RFC 3263)
- > QoS: 802.1p/Q tagging (VLAN), Layer 3 ToS DSCP
- > SRTP for voice
- > Transport Layer Security (TLS)
- > HTTPS certificate manager
- > AES encryption for configuration file
- > Digest authentication using MD5/MD5-session
- > OpenVPN, IEEE802.1X
- > IPv6
- > LLDP/CDP/DHCP VLAN
- > ICE

Package Features

- > Package content:
 - Yealink SIP-T23G IP phone
 - Handset with handset cord
 - Ethernet Cable (1.5m CAT5E UTP Cable)
 - Stand
 - Quick Start Guide
 - Power Adapter (Optional)
- > Qty/CTN: 10 PCS
- > N.W/CTN: 11.3 kg
- > G.W/CTN: 12.6 kg
- > Giftbox size: 215mm*200mm*118mm
- > Carton Meas: 615mm*436mm*208mm

Compliance

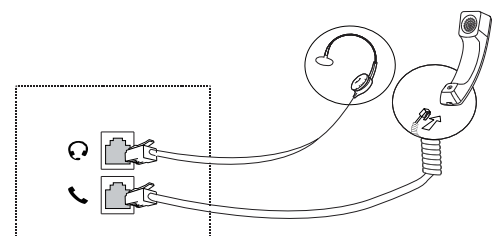
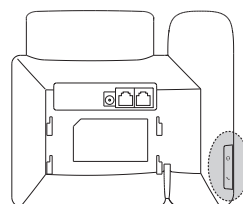
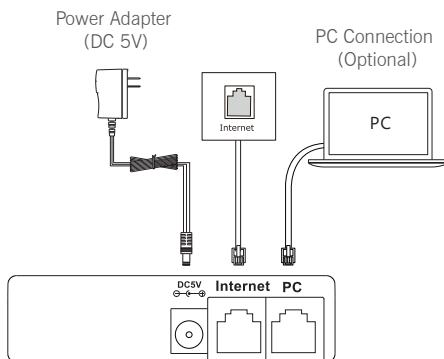

Learn More

To find out how Yealink solutions can help your organization, visit us at www.yealink.com or mail to sales@yealink.com



About Yealink

Yealink (Stock Code: 300628) is a global leading unified communication (UC) terminal solution provider that primarily offers video conferencing systems and voice communication solutions. Founded in 2001, Yealink leverages its independent research and development and innovation to pursue its core mission: "Easy collaboration, high productivity." The company's high-quality UC terminal solutions enhance the work efficiency and competitive advantages of its customers in over 100 countries. Yealink is the world's second-largest SIP phone provider and is number one in the China market.

Copyright

Copyright © 2017 YEALINK(XIAMEN) NETWORK TECHNOLOGY CO., LTD.

Copyright © 2017 Yealink(Xiamen) Network Technology CO., LTD. All rights reserved. No parts of this publication may be reproduced or transmitted in any form or by any means, electronic or mechanical, photocopying, recording, or otherwise, for any purpose, without the express written permission of Yealink(Xiamen) Network Technology CO., LTD.

Technical Support

Visit Yealink WIKI (<http://support.yealink.com/>) for firmware downloads, product documents, FAQ, and more. For better service, we sincerely recommend you to use Yealink Ticketing system (<https://ticket.yealink.com>) to submit all your technical issues.



YEALINK(XIAMEN) NETWORK TECHNOLOGY CO.,LTD.
Web: www.yealink.com
Addr: 309, 3th Floor, No.16, Yun Ding North Road,
Huli District, Xiamen City, Fujian, P.R. China
Copyright©2017Yealink Inc.All right reserved.